

# STANDARD OPERATING PROCEDURE

**Safe Use of Compressed Gas Cylinders**

Document Number: 960C-SOP-305

Original Approval Date: Mar 10, 2010

Revision Number: 3

Page 1 of 9

Latest Revision Date: Apr 12, 2022

Next Revision Date: Apr 12, 2025

Document Approval Level: 4

\*This document is not controlled if printed.\*

## SAFE USE OF COMPRESSED GAS CYLINDERS

**Gilbert Schreyer**  
  
**APR 14 2022**

Rev	Status	Rev. Date	Status Description	Prepared by	Reviewed by	Approved by
3	APP	Apr 12, 2022	Approved	Tammy Siver	Tammy Siver	Gilbert Schreyer
2	APP	Apr 24, 2012	Approved	Tammy Siver	Stan Miller	Stan Miller

# STANDARD OPERATING PROCEDURE

Safe Use of Compressed Gas Cylinders

Document Number: 960C-SOP-305

Original Approval Date: Mar 10, 2010

Revision Number: 3

Page 2 of 9

Latest Revision Date: Apr 12, 2022

Next Revision Date: Apr 12, 2025

Document Approval Level: 4

\*This document is not controlled if printed.\*

*The following is a step by step procedure on how to complete a specific task or meet a facility specific requirement. Standard Operating Procedures (SOPs) are written for all identified critical tasks. By virtue of the hazard or complexity associated with critical tasks it is paramount that the SOP be followed as written. SOPs contain a listing of high-level hazards associated with the task, for detailed hazard analysis reference the applicable Task Hazard Assessments. SOPs do not replace the requirements contained in the company Standards, Codes, and Processes nor does it replace the need to comply with required legislation. Section 8.0 references documentation that the worker shall understand before work commences.*

## 1.0 PURPOSE

- To establish a company standard to safely and effectively carry out work as it applies to the safe use of compressed gas cylinders.

## 2.0 SCOPE AND APPLICATION

- This document applies to all company Heavy Construction Mining operations. Ensure all site specific requirements are being met or exceeded before performing the task.

## 3.0 HAZARDS AND CONTROLS

- Gas leaks creating a hazardous environment.
  - Confirm valves are closed when not in use and all lines have been bled.
  - Ensure hose fittings are correct and tight and that gas delivery systems (hoses, pipes, tools, torches) are in good condition with no leak points.
  - Inspect hose, regulators and cylinders prior to use. Do not use a flame for inspection; in addition to a visual inspection, a leak test with soapy water may be used.
- Cylinder exploding or becoming a projectile.
  - Ensure the cylinder has a valve protection device in place whenever regulators are not attached and especially before moving or transporting it. Some valve protection devices are designed to cover the regulator and do not require the regulator to be removed. Confirm the cylinder is designed for this type of valve protection device if leaving the regulator in place.
  - Ensure the cylinder valve is shut off and pressure in the hose is released when cutting or welding is not in progress. Tiger torches must be removed from propane cylinder when not in use.
  - For hoses on an oxygen fuel system ensure, at a minimum, that a flashback device is installed at the regulator end and a back flow prevention device is installed at the torch end.
  - Do not assume the cylinder contents based colour indicators. Always check the labels.
  - Use a flow control regulator matched to the gas. Do not force a connection or alter any part of the assembly. Always inspect before use and complete a leak test.

# STANDARD OPERATING PROCEDURE

Safe Use of Compressed Gas Cylinders

Document Number: 960C-SOP-305

Original Approval Date: Mar 10, 2010

Revision Number: 3

Page 3 of 9

Latest Revision Date: Apr 12, 2022

Next Revision Date: Apr 12, 2025

Document Approval Level: 4

\*This document is not controlled if printed.\*

- Secure the cylinder at all times, especially when regulators are in place so the stem or regulators cannot be broken due to a fall.
- Do not overheat cylinder. Do not allow sparks, flames or other sources of ignition to come in contact with the cylinders, regulators or hoses.
- Do not drop the cylinder; do not lift a cylinder with a sling such that it could be dropped from a height.
- Do not press a cylinder with other materials/machinery and do not use a cylinder as a roller.
- Compressed gas cylinders must be kept clean and free from oil, grease and other contaminants that can cause the cylinder to explode, burn or fail. Ensure there are no smoking areas within 15 metres of storage area.
- Improper storage of compressed gas cylinders.
  - Store cylinders vertically in racks with a competent mechanism (i.e. chain) to secure them so that no cylinders may fall over.
  - Store incompatible substances away from each other.
  - Ensure racks are labelled and like cylinders are grouped together. Mark empty cylinders on the shoulder with a removable marker as "Empty or MT". Store them securely in the designated rack for empty cylinders. Ensure all cylinders are secured from movement.
  - Store oxygen and flammable gases separately by a minimum distance of six (6) metres or by a barrier of noncombustible material at least one (1) metre high with a fire resistance rating of at least 30 metres (this does not apply to single bottles "in use" such as on an oxy-acetylene cart).
  - Cylinders of Class 2.1 Flammable Gases (i.e. propane) or Class 2.3 Toxic or Corrosive Gases must be stored a minimum of 1.5 metres away from building openings when located outside.
  - Do not store propane inside when not in use.
  - Do not store compressed gas cylinders under stairs, fire escapes or building ramps.
  - All Class 2 Compressed Gas cylinders must be supported on raised concrete or other noncombustible platforms when stored outside. They must be protected from weather by a noncombustible canopy and be enclosed by a protective "fence" to protect against accidental damage to the cylinders.

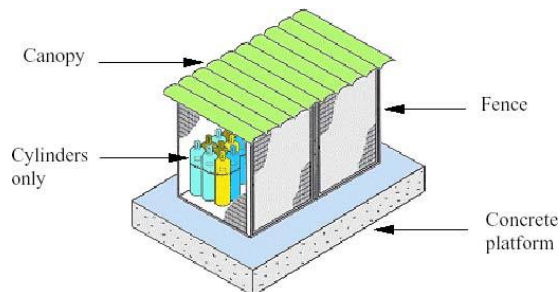

# STANDARD OPERATING PROCEDURE

Safe Use of Compressed Gas Cylinders

Document Number: 960C-SOP-305

Original Approval Date: Mar 10, 2010

Revision Number: 3

Page 4 of 9

Latest Revision Date: Apr 12, 2022

Next Revision Date: Apr 12, 2025

Document Approval Level: 4

\*This document is not controlled if printed.\*

- Improper transport of compressed gas cylinders.
  - Manually move cylinders with a dolly or other transport device; do not roll them. Confirm the tank has been secured to the dolly or rack using a chain or other suitable device. Inspect securing device to confirm integrity. For short moves such as out of a rack, they may be tilted slightly and rolled on their base rim only.
  - After movement, allow cylinders to sit for an appropriate time so they may stabilize. For example, acetylene must stand to allow the liquid acetone to settle and create a head of acetylene gas.
  - Follow Transportation of Dangerous Goods (Canada) or Department of Transportation (US) requirements if transporting compressed gas cylinders on a public road.
  - Mobile vehicle compressed gas enclosures must meet the company's requirements as outlined in Appendix A – Mobile Equipment Compressed Gas Enclosures Inspection Requirements, including:
    - Enclosures containing oxygen and acetylene gas cylinders must have adequate ventilation to prevent the buildup of explosive gases past their explosive limits. At a minimum, vents must provide 0.18m<sup>2</sup> (2 ft<sup>2</sup>) of free area for every 0.43 m<sup>3</sup> (15 ft<sup>3</sup>) of compartment volume.
    - Vents must be located on the top and bottom of the storage compartment to permit gases to rise or fall and leave the compartment. Door louvers are required if top free area is restricted.
    - Vents must remain unobstructed under all conditions (i.e. free of ice and snow build-up during winter operating conditions and free of mud and other debris at all times).
    - Latching and locking hardware must be made of non-sparking materials. Electrical fixtures or cables are not permitted within the compartment. If a cable is required within the compartment, it must be within explosion proof conduit.

## NACG CRITERIA FOR MOBILE EQUIPMENT ENCLOSURES

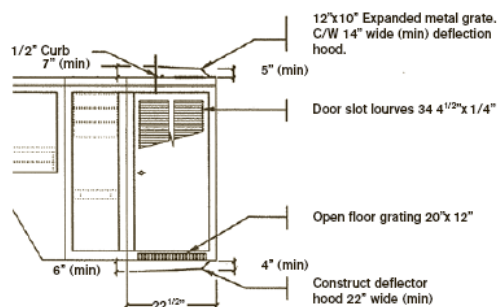

# STANDARD OPERATING PROCEDURE

<b>Safe Use of Compressed Gas Cylinders</b>		Document Number: 960C-SOP-305
Original Approval Date: Mar 10, 2010	Revision Number: 3	Page 5 of 9
Latest Revision Date: Apr 12, 2022	Next Revision Date: Apr 12, 2025	Document Approval Level: 4

\*This document is not controlled if printed.\*

- Compressed gas cylinders may be stored vertically or horizontally. All cylinders must be secured from movement. If a cylinder is stored horizontally, it must be in a compartment that has been certified by a professional engineer confirming the compartment is of sufficient strength to withstand a projectile cylinder, has an adequate securing device and is protected from scoring or damage.

## 4.0 CHECKLIST

- Attend all preparatory meetings (IE: daily PSI; job scope; review of JSA's and SOP's for the job)
- Complete FLRA cards before starting the work.
- Ensure all personnel involved in the task are aware of the hazards and the controls to be used, as identified in the SOP's; JSA's; and FLRA's.
- Conduct a pre-job inspection of all equipment to be worked on and tools to be used.
- Standard of Training required for working on this job: On-the job training.**

## 5.0 DEFINITIONS

### 5.1 Company

Means North American Construction Group Ltd. (NACG) and all directly or indirectly owned subsidiary companies, including joint ventures.

### 5.2 Company Personnel

Includes the Company's employees, officers, directors, agents, associates, consultants/contractors, temporary employees and third party processors.

### 5.3 HSE

Refers to the Health, Safety & Environment department.

## 6.0 PROCEDURE

- 1) Complete a hazard assessment (i.e. FLRA) for the task. Notify supervision if unsure of task or if there are hazards outside of the worker's control.
- 2) Select the compressed gases required for the task.
- 3) Assemble and inspect all compressed gas cylinders and gas delivery components (i.e. regulator, hoses, etc.). Complete a leak test as required. Remove from service any cylinder or component that is damaged, defective or leaking. Tagout and notify supervision.
- 4) Complete task.
- 5) Turn off valves and bleed hoses when not in use. Remove regulator and install valve protection device. If cylinder and valve protection device allow for the regulator to remain attached to the cylinder, the regulator may remain on the cylinder.
- 6) Return compressed gas cylinders to proper storage.

## 7.0 NOTES

If this task is to be done by a method different than described in this SOP, the work must **STOP** and the alternate method must be **DOCUMENTED** with an adequate hazard assessment tool such as a JSA. The document must be **APPROVED** by a supervisor before such procedures are implemented.

# STANDARD OPERATING PROCEDURE

**Safe Use of Compressed Gas Cylinders**

Document Number: 960C-SOP-305

Original Approval Date: Mar 10, 2010

Revision Number: 3

Page 6 of 9

Latest Revision Date: Apr 12, 2022

Next Revision Date: Apr 12, 2025

Document Approval Level: 4

\*This document is not controlled if printed.\*

## 8.0 REFERENCES

- Alberta Occupational Health and Safety Act, Regulation and Code – {Part 10, Section 171, Compressed and Liquefied Gas}
- 950C-C-007 Compressed Gas Cylinders Code
- 950C-C-028 Hazardous Energy Isolation Code
- Alberta Fire Code Part 3
- Ontario Fire Code Section 5.6 Compressed Gas Cylinders
- CSA W117.2-06 Safety in Welding, Cutting and Allied Processes

## 9.0 APPENDICES

- Appendix A – Vehicle Compressed Gas Enclosure Inspection Requirements
- Appendix B – Vehicle Compressed Gas Enclosure Inspection Form

# STANDARD OPERATING PROCEDURE

Safe Use of Compressed Gas Cylinders

Document Number: 960C-SOP-305

Original Approval Date: Mar 10, 2010

Revision Number: 3

Page 7 of 9

Latest Revision Date: Apr 12, 2022

Next Revision Date: Apr 12, 2025

Document Approval Level: 4

\*This document is not controlled if printed.\*

## Appendix A Vehicle Compressed Gas Enclosure Inspection Requirements

- All vehicles, including mechanical and welding trucks, to be used within the company will be subject to a full inspection at commencement of contract or employment. Inspections will be completed by a competent person designated by the company. Compressed gas enclosure inspections will be conducted thereafter on annual basis. Inspections will be documented on Appendix B – Vehicle Compressed Gas Enclosure Inspection Form.
- Upon satisfying the requirements of the inspection, a company issued decal for “Certified Compressed Gas Enclosure” is to be affixed to the top left corner of the enclosure door or in a conspicuous place on the weather hood located on the top of the cylinder compartment.
- All compartments should also have a “DANGER” decal affixed close to the lock/latch point of each enclosure used for storing or transporting inflammable compressed gas as well as a decal for “Compressed Gas Enclosure Restrictions”.
- Appropriate TDG labels must also be visible from outside of the vehicle.



### COMPRESSED GAS ENCLOSURE RESTRICTIONS

- > ABSOLUTELY NO OPEN FLAME OR OTHER IGNITION SOURCE.
- > ALL CYLINDERS MUST BE SECURED IN AN UPRIGHT POSITION.
- > CYLINDER GAUGES MUST BE REMOVED DURING TRANSPORT.
- > REMEMBER TO PURGE HOSES AND TORCH OF ANY REMAINING GAS BEFORE STORING.
- > PROTECTIVE CAPS MUST BE PLACED OVER CYLINDER VALVES WHEN NOT IN USE.
- > PROPANE AND OTHER FUEL GASES MUST BE STORED SEPARATELY IN THEIR OWN COMPARTMENT (NO OXYGEN WITH PROPANE.)
- > LIGHTS AND ELECTRICAL WIRING MAY NOT BE INSTALLED OR PASS THROUGH THIS ENCLOSURE.
- > THIS ENCLOSURE MUST REMAIN SEALED TO PREVENT THE MIGRATION OF LEAKED GASES INTO OTHER CABINETS.



Acetylene and Oxygen together, requires one Class 2.1 flammable (red) label and one oxidizing gas (yellow) label.

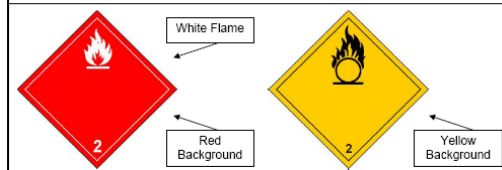

# STANDARD OPERATING PROCEDURE

**Safe Use of Compressed Gas Cylinders**

Document Number: 960C-SOP-305

Original Approval Date: Mar 10, 2010

Revision Number: 3

Page 8 of 9

Latest Revision Date: Apr 12, 2022

Next Revision Date: Apr 12, 2025

Document Approval Level: 4

\*This document is not controlled if printed.\*

## Appendix B Vehicle Compressed Gas Enclosure Inspection Form



<b>Monthly Inspection Report - Compressed Gas Cylinder Storage on Vehicles</b>		Document Number: 999C-F-065
Original Approval Date: Apr 13, 2022	Revision Number: 1	Page 1 of 1
Latest Revision Date: Apr 13, 2022	Next Revision Date: Apr 13, 2025	Document Approval Level: 5

\*This document is not controlled if printed.\*

<b>Owner of Equipment:</b>	<b>Unit#:</b>	
1. Are compressed gas cylinders being stored/transported on this unit?	<b>YES</b>	<b>NO</b>
2. Is the method of storage acceptable, with suitable provisions for securing all cylinders and proper allowance for ventilation if enclosed? <ul style="list-style-type: none"> <li>• <i>Propane must not be stored with any other compressed gas or oxygen.</i></li> <li>• <i>Must meet or exceed criteria for Mobile Equipment Enclosures engineered drawing.</i></li> </ul>	<b>YES</b>	<b>NO</b>
3. Are the compressed gas cylinders stored outside of the truck body and adequately protected?	<b>YES</b>	<b>NO</b>
4. Are proper TDG labels placed on the outside of the cabinet door and clearly visible?	<b>YES</b>	<b>NO</b>
5. Are flammable hazard stickers visible on the outside of the cabinet doors?	<b>YES</b>	<b>NO</b>
6. Is the Company's one year validation certification sticker visible on the outside of the cabinet door?	<b>YES</b>	<b>NO</b>
7. Is a flashback device installed at the regulator end and a back flow prevention device installed at the torch end of cutting equipment?	<b>YES</b>	<b>NO</b>
8. Are regulators in good condition?	<b>YES</b>	<b>NO</b>
9. Are hose connections secured with <u>proper</u> hose fittings and <u>proper</u> clamps?	<b>YES</b>	<b>NO</b>
10. Are the hoses in good condition with no visible deterioration at any of the clamped sections? Detached hoses must also be stored in an approved, vented enclosure.	<b>YES</b>	<b>NO</b>
11. Does the unit comply with the Company's Criteria for Mobile Equipment Enclosures as referenced in 960C-SOP-305 Safe use of Compressed Gas Cylinders?	<b>YES</b>	<b>NO</b>

The following improvements are required before this unit can go into service on any Company site:

\_\_\_\_\_

\_\_\_\_\_

This unit passed inspection in accordance with the standards prescribed by the Company.

\_\_\_\_\_  
**Inspector Name**

\_\_\_\_\_  
**Superintendent Name**

\_\_\_\_\_  
**Inspector Signature**

\_\_\_\_\_  
**Superintendent Signature**

\_\_\_\_\_  
**Date**

\_\_\_\_\_  
**Date**