

STANDARD OPERATING PROCEDURE

Crane Operation - Rubber Tire Gantry Crane

Document Number: 960C-SOP-407

Original Approval Date: Apr 09, 2018

Revision Number: 2

Page 1 of 6

Latest Revision Date: May 26, 2022

Next Revision Date: May 26, 2025

Document Approval Level: 4

This document is not controlled if printed.

CRANE OPERATION – RUBBER TIRE GANTRY CRANE

						
2	APP	May 26, 2022	Approved			Tammy Siver
1	APP	Apr 09, 2018	Approved	T. Siver	P. Judge	S. Miller
Rev	Status	Rev. Date	Status Description	Prepared by	Reviewed by	Approved by

STANDARD OPERATING PROCEDURE

Crane Operation - Rubber Tire Gantry Crane		Document Number: 960C-SOP-407
Original Approval Date: Apr 09, 2018	Revision Number: 2	Page 2 of 6
Latest Revision Date: May 26, 2022	Next Revision Date: May 26, 2025	Document Approval Level: 4

This document is not controlled if printed.

The following is a step-by-step procedure on how to complete a specific task or meet a facility specific requirement. Standard Operating Procedures (SOPs) are written for all identified critical tasks. By virtue of the hazard or complexity associated with critical tasks it is paramount that the SOP be followed as written. SOPs contain a listing of high-level hazards associated with the task, for detailed hazard analysis reference the applicable Task Hazard Assessments. SOPs do not replace the requirements contained in the company Standards, Codes, and Processes nor does it replace the need to comply with required legislation. Section 8.0 references documentation that the worker shall understand before work commences.

1.0 PURPOSE

- To establish a North American Construction Group Standard to safely and effectively carry out work as it applies to using a Rubber Tire Gantry Crane.

2.0 SCOPE AND APPLICATION

- This document applies to all NACG Heavy Construction and Mining operations. Ensure all site specific requirements are being met or exceeded before performing the task.

3.0 HAZARDS AND CONTROLS

- Unstable loads causing crane upset or damage.
 - Never lift a load using only the rear or front hoists. Always support the load between the front and rear hoists and distribute the load equally between the hoists.
 - Ensure gantry crane is set up on relatively firm, level ground. Where possible use concrete, asphalt or hard-packed gravel. A firm, well graded pad is sufficient as well.
 - Line up trolley with centre markers on bridge when lifting the load.
- Loads and or crane and rigging components shifting or swinging while crane is travelling.
 - Avoid sudden stops and quick starts. Operate all controls in a slow and steady manner.
 - Use the low speed range when transporting loads.
 - Ensure bridge and spreader bar are fully retracted into support saddles and centered on bridge if travelling without a load. Rigging cannot be attached when travelling.
- Loads exceeding lifting capacity of cranes.
 - Do not attempt to hoist a load if it is beyond the capacity of the machine. Confirm rated load capacity on the machine's identification plate.
 - Use the load indicator device to confirm the load is within lifting limits.
 - Do not shock load the machine. If the machine or its components have been shock loaded, it must be removed from service until such time that it has been inspected by a qualified person and re-certified for lifting.

STANDARD OPERATING PROCEDURE

Crane Operation - Rubber Tire Gantry Crane

Document Number: 960C-SOP-407

Original Approval Date: Apr 09, 2018

Revision Number: 2

Page 3 of 6

Latest Revision Date: May 26, 2022

Next Revision Date: May 26, 2025

Document Approval Level: 4

This document is not controlled if printed.

- Contact between crane and objects or personnel when crane is travelling.
 - Inspect travel route before moving crane to ensure there is adequate room and that the path is firm and level.
 - Use spotters; ensure primary spotter is identified with reflective arm band. Review hand and communication signals with all personnel before the task.
 - Use lighting plants as required for extra visibility.
 - Ground personnel are not permitted under trolleys while crane is travelling and must stay out of the line of travel.
 - Ground personnel are not permitted under suspended load.
 - Ensure load is lifted high enough to avoid contacting ground when travelling. Take into consideration elevation changes.
- Improper operation of crane.
 - Only trained, competent personnel are permitted to operate the gantry crane.
 - Do not drag a load. All loads must be lifted and carried.
 - When picking a load, ensure both wire ropes are in the vertical position. Do not place both hooks at the centre of a load; use a spreader bar as required to ensure centre of gravity is maintained.

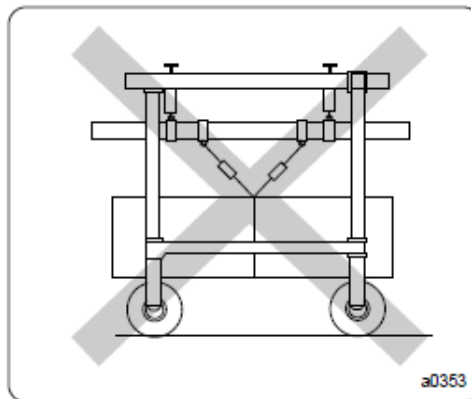
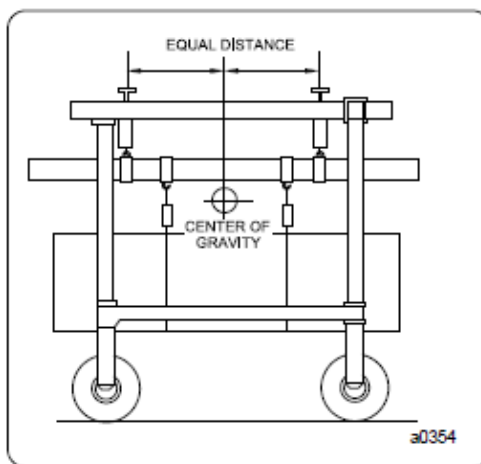

- Do not push or tow the gantry crane while it is under load.
 - Do not drive the gantry crane up an incline.
 - Do not use erratic or jerky movements when raising or lowering loads as this can break or damage hoist components.
 - Do not raise or lower more than 25% of the rated load in high speed.
- Falling while mounting or dismounting crane.
 - Always use 4x3 contact when mounting or dismounting the crane.
 - Do not carry anything while mounting or dismounting.

STANDARD OPERATING PROCEDURE

Crane Operation - Rubber Tire Gantry Crane		Document Number: 960C-SOP-407
Original Approval Date: Apr 09, 2018	Revision Number: 2	Page 4 of 6
Latest Revision Date: May 26, 2022	Next Revision Date: May 26, 2025	Document Approval Level: 4

This document is not controlled if printed.

- Inadequate or improper set up of rigging.
 - Inspect rigging, shackles, slings and lift pins; remove damaged or defective equipment.
 - Ensure rigging, shackles and slings are sufficient for the load being lifted.
 - Use softeners when slings are connected to sharp edges.
 - Make sure all pins and connections are secure before lifting.
 - Set rigging to proper spreader bar holes to safely maintain correct angle of sling to load being lifted. Follow lift plan.
- Pinch points and hand injuries when setting up rigging.
 - Wear gloves while handling rigging. Do not put fingers or hands between slings and lifting lugs/shackles.
- Unauthorized personnel in work area.
 - Flag or barricade the work area to ensure unauthorized personnel do not enter the area.
 - Only required personnel working on the task are permitted in the area.
 - No personnel are permitted under a suspended load.
- Contact with overhead hazards.
 - Inspect travel route before travelling with crane and ensure the crane can maintain a safe distance from powerlines and other overhead hazards.
- Unplanned or unintentional movement of crane.
 - Use wheel chocks on gantry crane when not in use and when crane is stationary while workers are setting up rigging.
 - Ensure parking brake is applied when crane is stationary or parked.

4.0 CHECKLIST

- Attend all preparatory meetings (IE: daily PSI; job scope; review of JSA's and SOP's for the job)
- Complete FLRA cards before starting the work.
- Ensure all personnel involved in the task are aware of the hazards and the controls to be used, as identified in the SOP's; JSA's; and FLRA's.
- Conduct a pre-job inspection of all equipment to be worked on and tools to be used.
- Standard of Training required for working on this job: On-the job training.**

5.0 DEFINITIONS

5.1 Company

Means North American Construction Group Ltd. (NACG) and all directly or indirectly owned subsidiary companies, including joint ventures.

5.2 Company Personnel

STANDARD OPERATING PROCEDURE

Crane Operation - Rubber Tire Gantry Crane		Document Number: 960C-SOP-407
Original Approval Date: Apr 09, 2018	Revision Number: 2	Page 5 of 6
Latest Revision Date: May 26, 2022	Next Revision Date: May 26, 2025	Document Approval Level: 4

This document is not controlled if printed.

Includes the Company's employees, officers, directors, agents, associates, consultants/contractors, temporary employees and third-party processors.

5.3 HSE

Refers to the Health, Safety & Environment department.

5.4 Gantry Crane

A bridge crane in which the beam or bridge is carried at each end by a trestle that travels on tracks on the ground.

5.5 Shock Load

With respect to a lifting device or its components, a sudden application of force or release of load. Any shock load requires the lifting device to be removed from service and re-certified for further lifting applications.

6.0 PROCEDURE

- 1) Prepare lift plan for the two (2) crane lift if using the gantry crane for a lift. Review JSA for task and complete FLRA.
- 2) Inspect rigging and ensure it is adequate size for task. Remove all damaged or defective rigging. Confirm load weights.
- 3) Inspect travel route (if travelling with crane) and ensure the ground is firm, level and free from obstacles. Confirm there are no overhead hazards or powerlines. Ensure there is a minimum of 40 feet width clearance to allow safe travel of crane.
- 4) Complete pre use inspection and walk around. Observe tires, cables, sheaves and drums as well as leaks or loose/missing/broken parts. Check to make sure emergency stop buttons are not pressed in and that wheels have been aligned. Document inspection in gantry crane logbook.
- 5) Use 4x3 contact to mount or dismount the gantry crane. Do not have anything in hands.
- 6) Fasten seatbelt and ensure parking brake is engaged. Sound horn, wait 5 seconds then start machine. Allow 2-3 minute warm-up period at low idle before applying load. Test steering, brakes and machine operation.
- 7) Using spotter(s), align crane with load being lifted. Ensure trolley has been lined up with centre markers on bridge. Once aligned, park crane and apply wheel chocks.
- 8) Attach rigging to load following JSA and lift plan specific to load being lifted.
- 9) Clear area of ground personnel; ensure no one is within trolleys or travel path of crane.
- 10) Using the load indicator display panel, confirm load is within machine limits. Select hoist speed and begin to raise load. Do not raise more than 25% of rated load in high speed. Both front and rear hoists can be operated simultaneously or one at a time. Raise load high enough for the task.

STANDARD OPERATING PROCEDURE

Crane Operation - Rubber Tire Gantry Crane		Document Number: 960C-SOP-407
Original Approval Date: Apr 09, 2018	Revision Number: 2	Page 6 of 6
Latest Revision Date: May 26, 2022	Next Revision Date: May 26, 2025	Document Approval Level: 4

This document is not controlled if printed.

- 11) Confirm trolleys are still aligned with centre markers on bridge. Set engine throttle to $\frac{3}{4}$ to full throttle. Confirm ground personnel are not in travel path. Sound horn once for travelling forward and twice for travelling in reverse. Release park brake and using controlled, slow movements begin travelling crane in forward or reverse to designated location. Ensure constant communication with primary spotter. Crane must stop if sight of primary spotter is lost at any time.
- 12) Once at designated location, stop crane and set park brake. Ground personnel will install wheel chocks. Using spotters, lower load onto designated location and remove rigging.
- 13) Ensure bridge and spreader bar are fully retracted into support saddles and centered on bridge before moving if travelling without a load. Rigging must be removed before travelling.

7.0 NOTES

If this task is to be done by a method different than described in this SOP, the work must **STOP** and the alternate method must be **DOCUMENTED** with an adequate hazard assessment tool such as a JSA. The document must be **APPROVED** by a supervisor before such procedures are implemented.

8.0 REFERENCES

- Alberta Occupational Health and Safety Act, Regulation and Code – {Part 6, Cranes, Hoists and Lifting Devices}
- 950C-C-008 Cranes, Hoists and Rigging Code
- 960C-SOP-403 Crane Operation – Shop Bridge Type

9.0 APPENDICES

No appendices.